

20W, Ultra wide input isolated & regulated dual / single output DC/DC converter



FEATURES

- Wide range of input voltage (4:1)
- Efficiency up to 90%
- No-load power consumption as low as 0.15W
- Isolation voltage : 1500VDC
- Input under-voltage protection, output short circuit protection, over-voltage protection, over-current protection
- Operating temperature range: -40°C to +85°C
- Meet CISPR22/EN55022 CLASS A
- Six-sided metal shielding package
- A2S (wiring mounting) and A4S (35mm rail mounting) products featuring reverse polarity protection for input
- Meet UL60950 , EN60950 and IEC60950

UL us CE CB Patent Protection RoHS



URA_LD-20WR3 & URB_LD-20WR3 series are isolated 20W DC-DC products with 4:1 input voltage. They feature efficiency up to 90%, 1500VDC isolation, operating temperature of -40°C ~ +85°C, Input under-voltage protection, output short circuit protection, over-voltage protection, over-current protection and EMI meets CISPR22/EN55022 CLASS A, which make them widely applied in data transmission device, battery power supplies, tele-communication device, distributed power supply system, remote control system, industrial robot system fields. And extension package A2S and A4S also enable them with reverse voltage protection.

Selection Guide

Certification	Part No. ①	Input Voltage (VDC)		Output		Efficiency ^③ (%.Min./Typ.) @ Full Load	Max. Capacitive Load ^④ (μF)
		Nominal (Range)	Max. ②	Output Voltage (VDC)	Output Current (mA)(Max./Min.)		
UL/CE/CB	URA2405LD-20WR3	24 (9-36)	40	±5	±2000/0	84/86	4800
	URA2409LD-20WR3			±9	±1111/0	86/88	1000
	URA2412LD-20WR3			±12	±834/0	86/88	800
	URA2415LD-20WR3			±15	±667/0	86/88	625
	URB2403LD-20WR3			3.3	5000/0	84/86	10000
	URB2405LD-20WR3			5	4000/0	88/90	10000
	URB2409LD-20WR3			9	2222/0	87/89	4700
	URB2412LD-20WR3			12	1667/0	87/89	1600
	URB2415LD-20WR3			15	1333/0	88/90	1000
	URB2424LD-20WR3			24	834/0	88/90	500
--	URA4805LD-20WR3	48 (18-75)	80	±5	±2000/0	84/86	4800
	URA4812LD-20WR3			±12	±834/0	86/88	800
	URA4815LD-20WR3			±15	±667/0	87/89	625
	URB4803LD-20WR3			3.3	5000/0	84/86	10000
	URB4805LD-20WR3			5	4000/0	88/90	10000
UL/CE/CB	URB4809LD-20WR3			9	2222/0	87/89	4700
	URB4812LD-20WR3			12	1667/0	87/89	1600
	URB4815LD-20WR3			15	1333/0	88/90	1000
	URB4824LD-20WR3			24	834/0	88/90	500

Notes: ① Series with suffix "H" are heat sink mounting; series with suffix "A2S" are chassis mounting, with suffix "A4S" are DIN-Rail mounting, for example URB2405LD-20WHR3A2S is chassis mounting of with heat sink, URB2405LD-20WR3A4S is DIN-Rail mounting of without heat sink; If the application has a higher requirement for heat dissipation, you can choose modules with heat sink;
 ② Absolute maximum rating without damage on the converter, but it isn't recommended;
 ③ Efficiency is measured in nominal input voltage and rated output load; A2S (wiring) and A4S (rail) Model due to input reverse polarity protection, minimum efficiency greater than Min.-2 is qualified;
 ④ The capacitive loads of positive and negative outputs are identical.

Input Specifications

Item	Operating Conditions		Min.	Typ.	Max.	Unit
Input Current (full load / no-load)	24VDC input	3.3V output	--	799/40	818/45	mA
		5V output	--	969/40	993/45	
		Others	--	948/6	941/10	
	48VDC input	3.3V output	--	400/20	409/25	
		5V output	--	485/20	497/25	
		Others	--	474/5	485/9	
Reflected Ripple Current	24VDC input		--	30	--	
	48VDC input		--	30	--	
Input impulse Voltage (1sec. max.)	24VDC input		-0.7	--	50	
	48VDC input		-0.7	--	100	
Starting Voltage	24VDC input		--	--	9	VDC
	48VDC input		--	--	18	
Under Voltage Shutdown	24VDC input		5.5	6.5	--	
	48VDC input		14.0	15.5	--	
Starting Time	Nominal input& constant resistance load		--	10	--	ms
Input Filter			Pi filter			
Ctrl*	Module switch on		Ctrl suspended or connected to TTL high level (3.5-12VDC)			
	Module switch off		Ctrl pin connected to GND or low level (0-1.2VDC)			
		Input current when switched off	--	4	7	mA
Hot Plug			Unavailable			

Note: *The voltage of Ctrl pin is relative to input pin GND.

Output Specifications

Item	Operating Conditions		Min.	Typ.	Max.	Unit
Output Voltage Accuracy ^①	0%-100% load		--	±1	±3	
Balance of Output Voltage	Dual output, balanced load		--	±0.5	±1.5	
Line Regulation	Full load, the input voltage is from low voltage to high voltage	Positive Output	--	±0.2	±0.5	%
		Negative Output	--	±0.5	±1	
Load Regulation ^②	5%-100% load	Positive Output	--	±0.5	±1	%
		Negative Output	--	±0.5	±1.5	
Cross Regulation	Dual output, main output 50% load, Supplement output from 10% to 100% load		--	--	±5	
Transient Recovery Time	25% load step change		--	300	500	μs
Transient Response Deviation		3.3V/5V/±5V output	--	±5	±8	%
	Others	--	±3	±5		
Temperature Drift Coefficient	Full load		--	--	±0.03	%/°C
Ripple & Noise ^③	20MHz bandwidth, 5%-100% load		--	50	100	Mv p-p
Trim			--	±10	--	%Vo
Over-voltage Protection	Input voltage range		110	--	160	
Over-current Protection			110	--	190	%Io
Short circuit Protection			Hiccup, Continuous, self-recovery			

Note:①At 0%~5% load, the Max. output voltage accuracy of ±5VDC/±9VDC output converter is ±5%.

②When testing from 0% to 100% load working conditions, load regulation index of ±5%;

③0%-5% load ripple&Noise is no more than 5%Vo. Ripple and noise are measured by "parallel cable" method, please see DC-DC Converter Application Notes for specific operation.

General Specifications

Item	Operating Conditions	Min.	Typ.	Max.	Unit
Insulation Voltage	Input-output, with the test time of 1 minute and the leak current lower than 1mA	1500	--	--	VDC
Insulation Resistance	Input-output, insulation voltage 500VDC	1000	--	--	MΩ
Isolation Capacitance	Input-output, 100KHz/0.1V	URB2424LD-20WR3	--	2050	pF
		Others	--	1050	
Operating Temperature	see Fig. 1	-40	--	+85	℃
Storage Temperature		-55	--	+125	
Storage Humidity	Non-condensing	5	--	95	%RH
Pin Welding Resistance Temperature	Welding spot is 1.5mm away from the casing, 10 seconds	--	--	+300	℃
Vibration		10-55Hz, 10G, 30 Min. along X, Y and Z			
Switching Frequency *	PWM mode	--	270	--	KHz
MTBF	MIL-HDBK-217F@25℃	1000	--	--	K hours

Note:* This series of products using reduced frequency technology, the switching frequency is test value of full load,When the load is reduced to below 50%, the switching frequency decreases with decreasing load.

Physical Specifications

Casing Material			Aluminum alloy
Dimension	Horizontal package(without heat sink)		50.80*25.40*11.80 mm
	Horizontal package(with heat sink)		50.80*25.40*16.30 mm
	A2S wiring package (without heat sink)		76.00*31.50*21.20 mm
	A2S wiring package(with heat sink)		76.00*31.50*25.10 mm
	A4S rail package(without heat sink)		76.00*31.50*25.80 mm
	A4S rail package(with heat sink)		76.00*31.50*29.70 mm
Weight	without heat sink	Horizontal package/A2S wiring package/A4S rail package	26.00g/48.00g/68.00g(Typ.)
	with heat sink	Horizontal package/A2S wiring package/A4S rail package	34.00g/56.00g/76.00g(Typ.)
Cooling Method			Free convection

EMC Specifications

EMI	CE	CISPR22/EN55022 CLASS A (Bare component)/ CLASS B (see Fig.3-② for recommended circuit)	
	RE	CISPR22/EN55022 CLASS A (Bare component)/ CLASS B (see Fig.3-② for recommended circuit)	
EMS	ESD	IEC/EN61000-4-2	Contact ±4KV perf. Criteria B
	RS	IEC/EN61000-4-3	10V/m perf. Criteria A
	EFT	IEC/EN61000-4-4	±2KV (see Fig.3-① for recommended circuit) perf. Criteria B
	Surge	IEC/EN61000-4-5	±2KV (see Fig.3-① for recommended circuit) perf. Criteria B
	CS	IEC/EN61000-4-6	3 Vr.m.s perf. Criteria A
	Voltage dips, short interruptions and voltage variations immunity		IEC/EN61000-4-29

Product Characteristic Curve

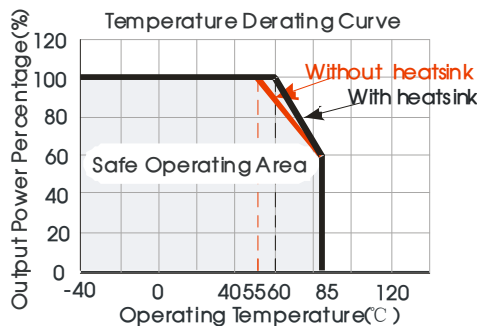
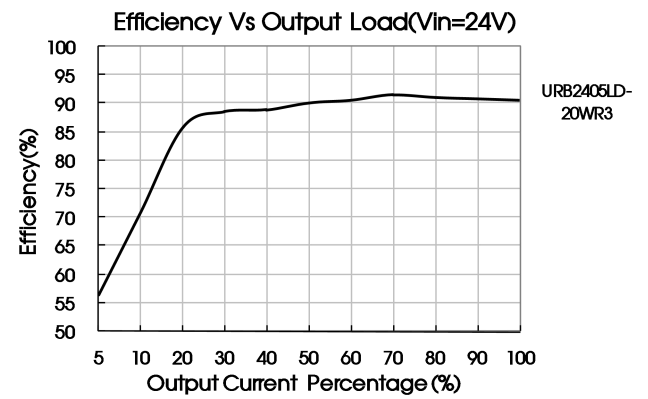
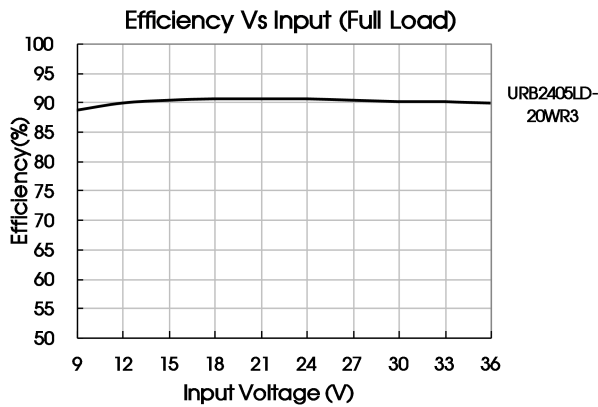
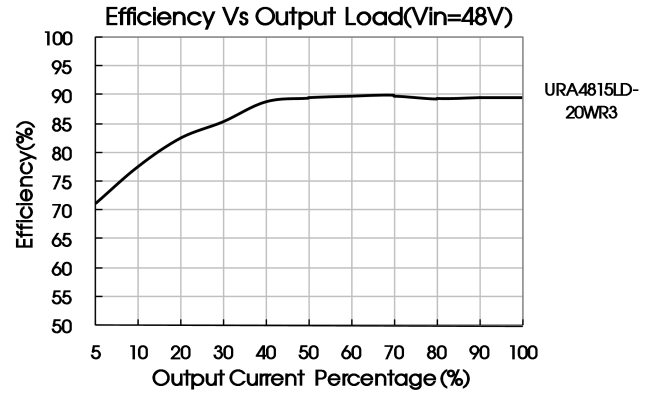
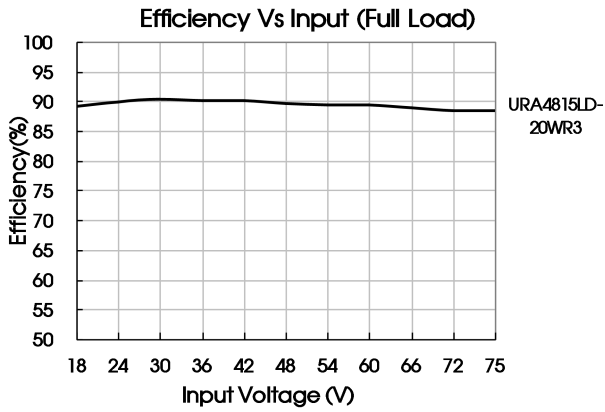

Fig. 1



Design Reference

1. Typical application

All the DC/DC converters of this series are tested according to the recommended circuit (see Fig. 2) before delivery. If it is required to further reduce input and output ripple, properly increase the input & output of additional capacitors C_{in} and C_{out} or select capacitors of low equivalent impedance provided that the capacitance is no larger than the max. capacitive load of the product.

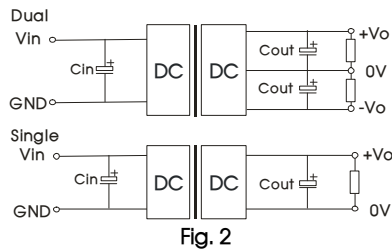

Single Vout (VDC)	Cout (μ F)	Cin (μ F)	Dual Vout (VDC)	Cout (μ F)	Cin (μ F)
3.3/5	470	100	± 5	220	100
9/12/15	220		$\pm 9/\pm 12/\pm 15$	100	
24	100		--	--	

2. EMC solution-recommended circuit

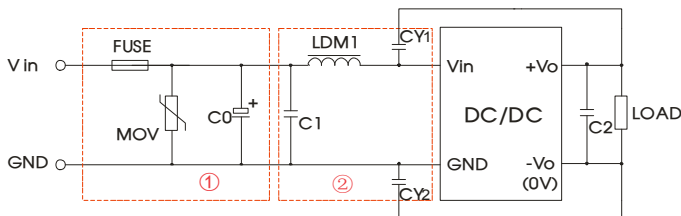

Notes: Part ① in the Fig. 3 is used for EMS test and part ② for EMI filtering; selected based on needs.

Parameter description

Model	Vin:24V	Vin:48V
FUSE	Choose according to actual input current	
MOV	S14K35	S14K60
C0	330 μ F/50V	330 μ F/100V
C1	1 μ F/50V	1 μ F/100V
C2	Refer to the Cout in Fig.2	
LDM1	4.7 μ H	
CY1/ CY2	1nF/2KV	

EMC solution-recommended circuit PCB layout

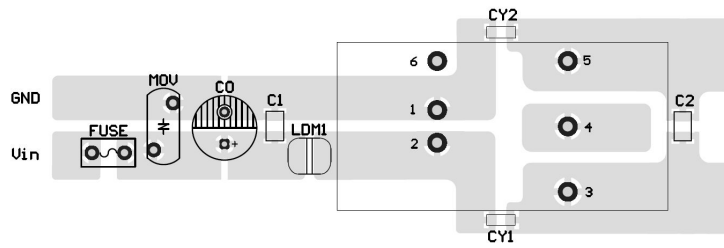
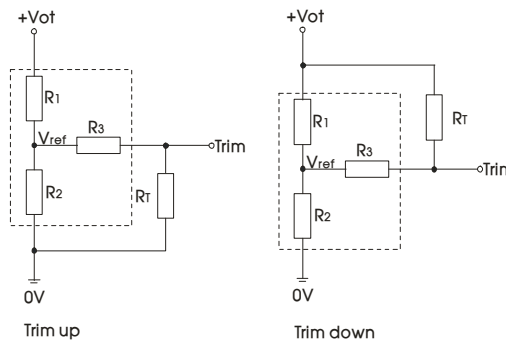

Fig. 4

Note: the min. distance of the bonding pads between input & output isolation capacitors (CY1/CY2) shall be ≥ 2mm.

3. Application of Trim and calculation of Trim resistance



Applied circuits of Trim (Part in broken line is the interior of models)

Calculation formula of Trim resistance:

$$\begin{aligned} \text{up: } R_T &= \frac{\alpha R_2}{R_2 - \alpha} - R_3 & \alpha &= \frac{V_{ref}}{V_o' - V_{ref}} \cdot R_1 \\ \text{down: } R_T &= \frac{\alpha R_1}{R_1 - \alpha} - R_3 & \alpha &= \frac{V_o' - V_{ref}}{V_{ref}} \cdot R_2 \end{aligned}$$

R_T is Trim resistance
 α is a self-defined parameter, with no real meaning.

Vout(V)	R1(KΩ)	R2(KΩ)	R3(KΩ)	Vref(V)
3.3	4.801	2.87	12.4	1.25
5	2.883	2.87	10	2.5
9	7.500	2.87	15	2.5
12	11.000	2.87	15	2.5
15	14.494	2.87	15	2.5
24	24.872	2.87	17.8	2.5

4. It is not allowed to connect modules output in parallel to enlarge the power

5. For more information please find DC-DC converter application notes on www.mornsun-power.com

Horizontal Package (without heat sink) Dimensions and Recommended Layout

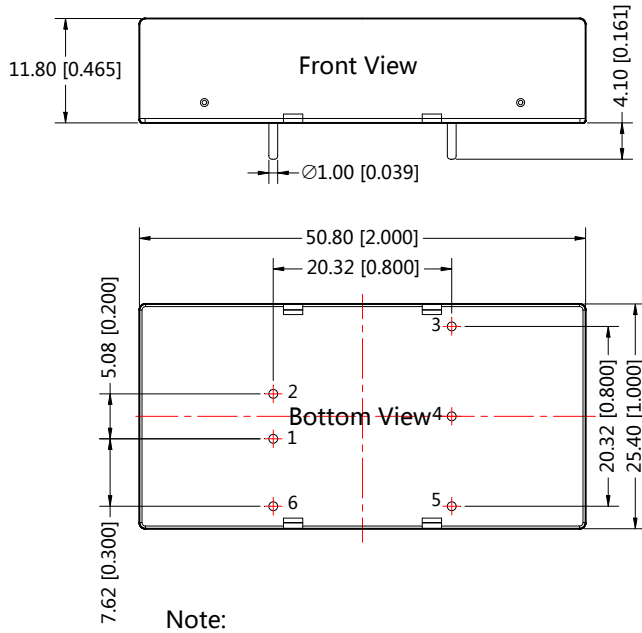

Note:
Unit :mm[inch]
Pin diameter tolerances :±0.10[±0.004]
General tolerances:±0.50[±0.020]

THIRD ANGLE PROJECTION

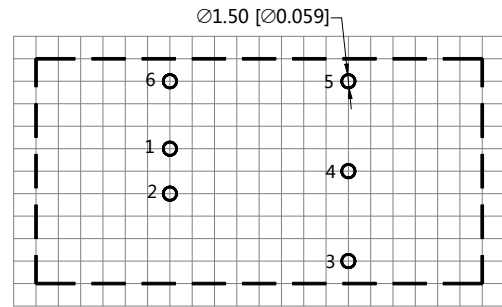

Note : Grid 2.54*2.54mm

Pin-Out		
Pin	Single	Dual
1	GND	GND
2	Vin	Vin
3	+Vo	+Vo
4	Trim	0V
5	0V	-Vo
6	Ctrl	Ctrl

Horizontal Package (with heat sink) Dimensions

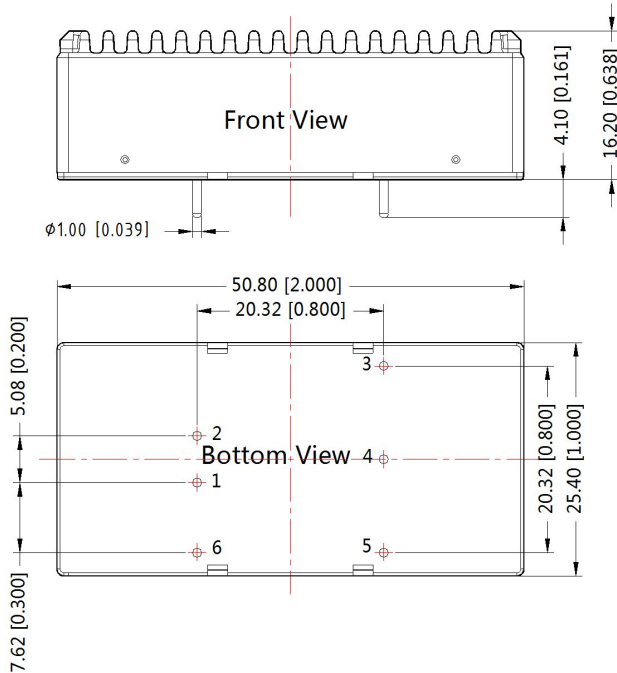

Note:
Unit :mm[inch]
General tolerances:±0.50[±0.020]

THIRD ANGLE PROJECTION

Pin-Out		
Pin	Single	Dual
1	GND	GND
2	Vin	Vin
3	+Vo	+Vo
4	Trim	0V
5	0V	-Vo
6	Ctrl	Ctrl

URA_LD-20WR3A2S & URB_LD-20WR3A2S(without heat sink) Dimensions

THIRD ANGLE PROJECTION

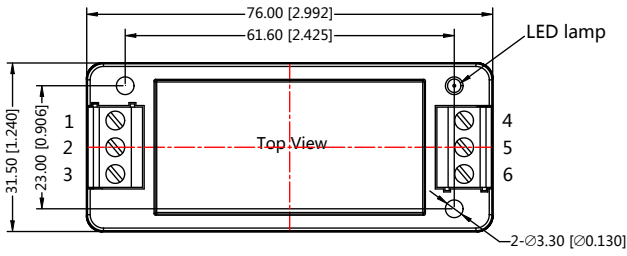

Pin-Out						
Pin	1	2	3	4	5	6
Dual	Ctrl	GND	Vin	-Vo	0V	+Vo
Single	Ctrl	GND	Vin	0V	Trim	+Vo

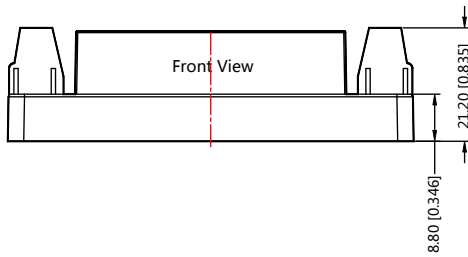

Note:
 Unit:mm[inch]
 Wire range : 24~12 AWG
 General tolerances:±0.50[±0.020]

URA_LD-20WHR3A2S & URB_LD-20WHR3A2S(with heat sink) Dimensions

THIRD ANGLE PROJECTION

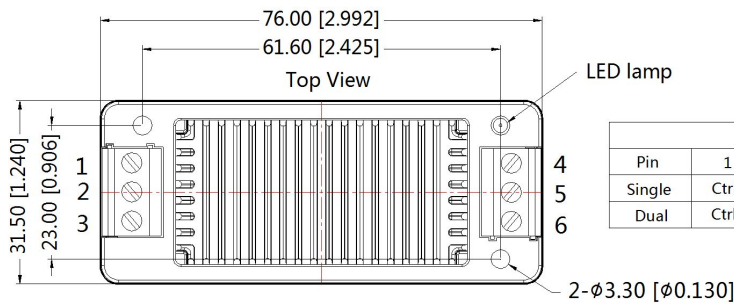

Pin-Out						
Pin	1	2	3	4	5	6
Single	Ctrl	GND	Vin	0V	Trim	+Vo
Dual	Ctrl	GND	Vin	-Vo	0V	+Vo

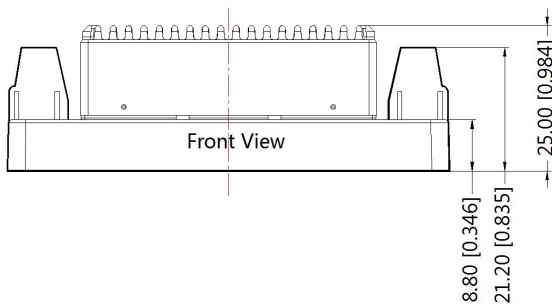

Note:
 Unit:mm[inch]
 Wire range:24~12 AWG
 General tolerances:±0.50[±0.020]

URA_LD-20WR3A4S & URB_LD-20WR3A4S(without heat sink) Dimensions

THIRD ANGLE PROJECTION

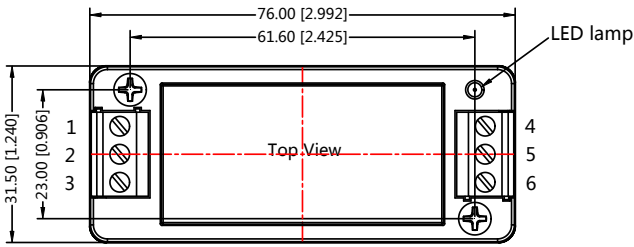

Pin-Out						
Pin	1	2	3	4	5	6
Dual	Ctrl	GND	Vin	-Vo	0V	+Vo
Single	Ctrl	GND	Vin	0V	Trim	+Vo

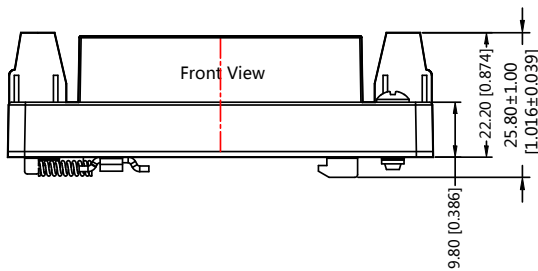

Note:
 Unit:mm[inch]
 Wire range : 24~12 AWG
 General tolerances:±0.50[±0.020]

URA_LD-20WHR3A4S & URB_LD-20WHR3A4S(with heat sink) Dimensions

THIRD ANGLE PROJECTION

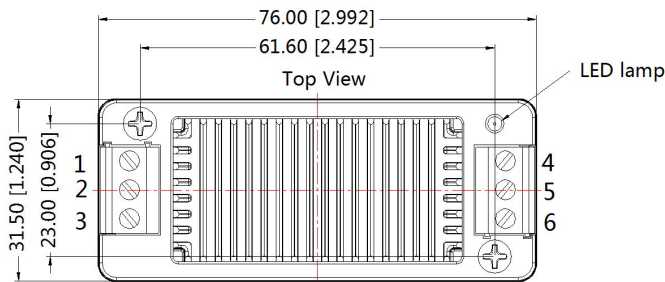

Pin-Out						
Pin	1	2	3	4	5	6
Single	Ctrl	GND	Vin	0V	Trim	+Vo
Dual	Ctrl	GND	Vin	-Vo	0V	+Vo

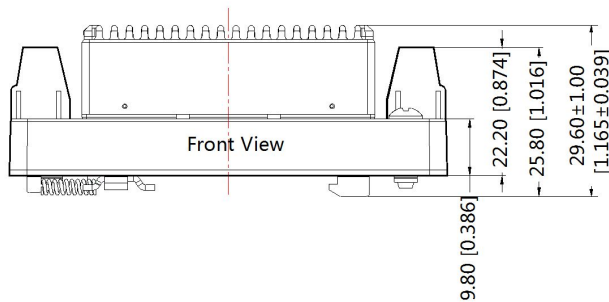

Note:
 Unit:mm[inch]
 Wire range:24~12 AWG
 General tolerances:±0.50[±0.020]

Notes:

1. Packing information please refer to Product Packing Information which can be downloaded from www.mornsun-power.com. The Packing bag number of Horizontal package :58200035(without heat sink), 58200051(with heat sink, A2S/ A4S package number: 58220022;
2. The recommended unbalance degree of the dual output module load is $\leq \pm 5\%$; if the degree exceeds $\pm 5\%$, than the product performance cannot be guaranteed to comply with all parameters in the datasheet. Please contact our technicians directly for specific information;
3. The maximum capacitive load offered were tested at nominal input voltage and full load;
4. Unless otherwise specified, parameters in this datasheet were measured under the conditions of $T_a=25^\circ\text{C}$, humidity $<75\%$ with nominal input voltage and rated output load;
5. All index testing methods in this datasheet are based on our Company's corporate standards;
6. The performance parameters of the product models listed in this manual are as above, but some parameters of non-standard model products may exceed the requirements mentioned above. Please contact our technicians directly for specific information;
7. We can provide product customization service;
8. Specifications are subject to change without prior notice.

Mornsun Guangzhou Science & Technology Co., Ltd.

Address: No. 5, Kehui St. 1, Kehui Development Center, Science Ave., Guangzhou Science City, Luogang District, Guangzhou, P. R. China
Tel: 86-20-38601850-8801 Fax: 86-20-38601272 E-mail: info@mornsun.cn